

# Against All Odds: Commercial Sound Recording and Reproduction in Analog Times

George Brock-Nannestad

*Postal:*

Patent Tactics  
Resedavej 40, DK-2820  
Gentofte, Denmark

*Email:*

gbn@newmail.dk

*Today sound recording is for everyone, but for the first 100 years, it was very mechanical and complex.*

## Introduction

We are surrounded by recorded sound wherever we go, and we have access to the largest selection ever of recorded sound via personal devices such as the iPod or from the Web. Development in sound recording has spanned more than 125 years, over which time we have seen continuous technical progress from extremely primitive beginnings (Hoffmann, 2005).

Today, audio technology is predominantly digital, which places it on a very solid footing in which storage is actually a computer file that is amenable to backup so that we shall never lose anything! But the earlier technologies comprising analog recording systems still account today for the majority of sound that has ever been recorded. There is, hence, a good reason to look back at early recordings (Nixon, 1945; Olson, 1954).

The time limit of the present overview is about 1960 because by then the analog medium of widest distribution, the mechanical record, was fully matured. It was then overtaken by the more democratic utility, the magnetic tape compact cassette, which, however, had a less inherent quality. Sound records have always been used both commercially and professionally.

Historical overviews risk being overburdened with detail, in particular when dealing with such a broad field as sound recording and reproduction, which draws on so many phenomena and involves mechanics, acoustics, electronics, and chemistry. Development was explosive starting in 1887, and we need to concentrate on the surviving technologies. In the United Kingdom alone, about 4,000 patents were published on phonograph-related inventions until about 1960, but only a few hundred had any lasting impact. Some readers with specialized knowledge will undoubtedly find gaps in this presentation. However, a selection of the relevant literature is given in References to aid further exploration of the subject. A German (Bergtold, 1959) and a French (Gilotaux, 1971) reference are also included.

Sound recording technology starts with a transducer and ends with a transducer. The actual element that interacts with the sound pressure variations is a diaphragm. The sound that we are interested in is picked up by a microphone diaphragm, which converts the sound into an electrical signal that is a representation of the sound pressure variations. The electrical signal is taken to a storage device, and when we want to listen to the sound, the electrical signal is sent to an amplifier, which drives a loudspeaker or headphones. Apart from a means for storing the signal, a public address system has the same components (Beranek, 1954).

Looking at it this way, one can say that storage is really only a delay, which may be quite long. This was an absolute truth in the days when it was only possible to record live sound and before mixing and editing became essential in record production.

All imaginable types of analog storage were contemplated and tried over the last century but only one became commercial in the sense of “widespread.” That was the mechanical record that relies on modifying the surface structure of a record.

In the very early days of analog recording, storage was entirely dependent on converting the vibrations of the diaphragm directly into a displacement of the surface of a storage medium, a record. Later, it was found that it was possible to use a microphone and an amplifier to transfer the electrical signal from the microphone into its physical form on a storage medium. This required further transducers, both to read into the storage medium and to pick the signal off when the recording was played. Today, we only need the input and the output because everything else is fully electronic and digitally coded.

### **The First Implementation of Ideas for Recording Sounds for Later Analysis, 1857**

From merely considering sound as something that was perceived by the ear was in itself a major paradigm shift when it was realized that the sound was related to vibration and that some vibrations caused pressure variations in the air around the barometric mean (Beyer, 1999). Furthermore, it was discovered that a diaphragm would vibrate when it was hit by a sound.

Graphic observation of sound pressure variations came into the scientific world with Léon Scott of Paris, France, who developed his phonautograph in 1857. In essence, it was a sound collector with a diaphragm and a scribe combined with a kymograph (Brock-Nannestad, 2014). The famous physical instrument manufacturer Rudolph Koenig (Pantolony, 2009) manufactured Scott’s invention from 1859 under a patent license (Brock-Nannestad, 2007), and it remained in his and his successors’ catalogues until about 1920. Scott and Koenig had different views on the phonautograph’s use; Koenig wanted to observe harmonics in complex sounds, storing the results and demonstrating physical relationships, whereas Scott wished to characterize the patterns of speech.

Their problematic relationship was exacerbated by Scott’s failure to renew his patent (Brock-Nannestad and Fontaine, 2008).

### **The First Implementation of Ideas for Retrieving a Sound from a Recording, 1877**

Charles Cros, a French poet and inventor, considered that it might be possible to use the undulating tracings from a phonautograph in connection with photoengraving to etch grooves in a surface. Such a groove could make a needle vibrate when it was pulled along the groove, and the vibrations would correspond to the waveshape of the original sound. He did not demonstrate his process in practice.

At the same time, Thomas Alva Edison in the United States was experimenting with recording the actual excursions of a diaphragm that received sound, and he demonstrated reproduced sound from a cylindrical surface that had been deformed by the receiving diaphragm via a stylus in an ensemble called a “soundbox.” He used a second soundbox with a reproducing stylus and diaphragm and was able to obtain recognizable sound. In other words, sound recording technology started with the diaphragm doing real work! This was the basis for vertical or “hill-and-dale” recording, but Edison did not develop his principle further at the time.

This initiative was taken at the Volta Laboratory in Washington, DC, by Chichester Bell and Charles Sumner Tainter, who devised a wax substance that could be cut into by a lathe-type machine tool and subsequently replayed and even shaved to obtain a new fresh recording surface. A horn or funnel collected the sound and led it to a capsule with a diaphragm that drove a cutting stylus. The Volta Laboratory development eventually led to the establishment of the Columbia Graphophone Co., and their main competitor in the cylinder field became Edison after his company reentered the field. The first intended use was for dictation, but later the idea of “canned music” (John Philip Sousa’s derogatory term) was developed into the recording industry.

### **Business Sense: Both Hardware and Software**

In the beginning, record companies had two products: phonographs and the records for them. It is difficult to distinguish which one was the most important. The wish of the companies was that their records sounded good on their own machines. The records had to resemble the original art-

ists as much as possible, that is, a brass band should sound like a brass band, a famous singer should be recognizable, and an orchestral accompaniment should sound convincing. Due to the various distortions and limitations of the early recording and reproducing equipment, they had to “cheat” by modifying the sound that was recorded so that the result was as purported by the record label when it was played. Still they claimed that they represented the artist in the best way. That is a tradition that has continued to this day and is the basis for the work of the modern record producer.

### The Wish for a Strong Sound

The phonograph reproducing a record was competing with live instruments, and for this reason, it was desired that the reproduction be loud, particularly when performing outdoors. The first experiments used a mechanical amplifier in which a small reproducing diaphragm controlled a larger force from a rotating pulley that drove a large diaphragm and a large reproducing horn. But the real breakthrough came when Charles Parsons in the United Kingdom in 1903 developed the Auxetophone in which the reproducing diaphragm was replaced by a valve that controlled pressurized air (Parsons, 1904). This amplifier enabled phonograph concerts in public parks. In 1916, Peter Jensen and Edwin Pridham in Oakland, CA, demonstrated the first electrically amplified public address system that was developed into the Magnavox loudspeaker, which provided limitless power to radiate any sound from an electrical signal, such as for a public address.

### Use of Old Principles for Sound Retrieval, 1887

Cylinders were simple to record and replay, but commercial manufacture that involved casting in a mold was difficult and had to rely on the contraction of the wax when it had cooled in its cylindrical mold. Emile Berliner realized that the ideas of Charles Cros were fertile and in 1887 first developed a practical photo-reproducing method for etching grooves in a flat disc and then realized that it was possible to dispense with the optical step. The recording stylus only needed to scratch through a thin layer of wax to expose a metal surface below so that a spiral groove could be etched by an acid after recording. He also devised a method to make a negative impression of the groove, which he could use as a stamper to manufacture disc records. His grooves were lateral and not nearly as shallow as a hill-and-dale groove, and he obtained a very strong basic patent on letting the groove guide the reproducing stylus across the record. We now had

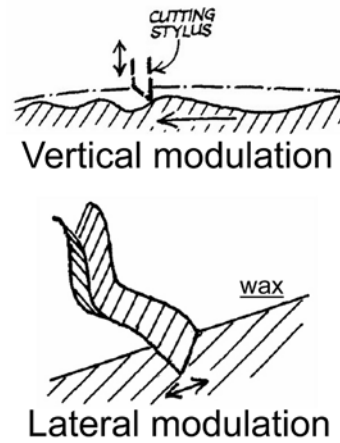

*Figure 1. The two kinds of modulation of a groove in a record: the vertical (or hill-and-dale; top) that modulates the depth of cut and the lateral (or Berliner; bottom) in which the spiral groove is made “wob-bly” by a sideways movement of the cutting stylus. Copyright © 1983 George Brock-Nannestad.*

two groove structures available: the vertical or hill-and-dale and the lateral (sometimes called “Berliner”). These are shown in **Figure 1**.

### The Surviving Method of Mechano-Acoustic Recording, Until 1925

The two-stage process of obtaining a groove by etching required the use of strong chemicals in the recording studio, and this method produced noisy grooves. For this reason, Eldridge R. Johnson (later president of the Victor Talking Machine Company) refined a process that had originally been demonstrated by the Volta Laboratory, which was directly cutting the groove into a waxlike tablet. The groove, considered as a zero line, was modulated by a stylus that was vibrated by the diaphragm.

When the recording was obtained in the wax, it was extremely fragile, and even though very gentle reproduction soundboxes were used for listening to the wax recording, it became useless for further processing. To obtain test records for proper evaluation, it was necessary to pass through several stages of electrolytic deposit; the wax surface was made conductive by means of very finely divided graphite and bronze powder, with the surplus brushed off by means of a very soft brush. Copper plating was performed to obtain a negative, and it was quickly discovered that although you could press a run of perhaps 200-300 records from the negative, it ultimately wore out and delivered a low-quality reproduction of sound. For this reason, two further plating steps were introduced: from the original negative a positive was made and from that the proper tool, the stamper. When the stamper was worn out, one could produce another identical one from the positive. This complicated process is shown schematically in **Figure 2** and it remains in the industry and is still in use, although the materials are different. The provision of the consumer goods, a record, therefore relied on a large supporting industry. The large part played by industrial chemistry is not for this account.

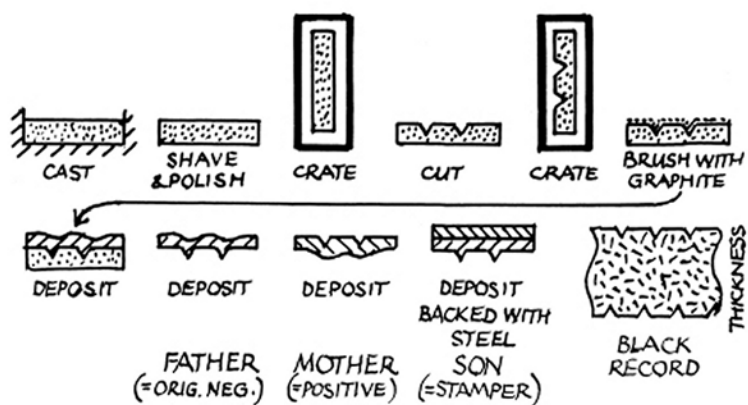
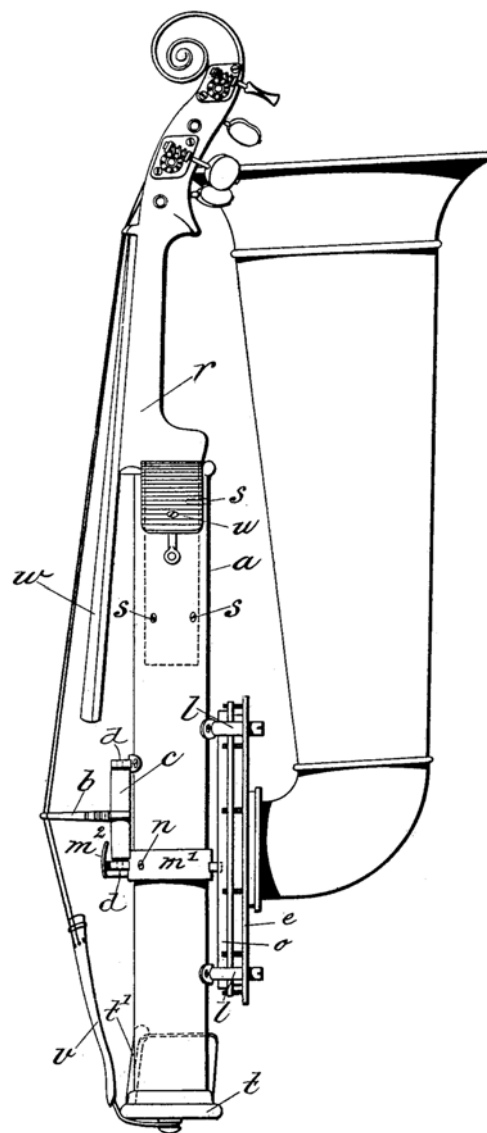

**Figure 2.** Steps in the process from wax to published record. The flat wax “cake” is given a shiny surface, shipped to where it is recorded, and then shipped to the factory electrotypical department where a stamper for the records is prepared. Copyright © 1983 George Brock-Nannestad.

In the beginning, only the cornet, banjo, and tenor voice were really good for recording this way, but the record companies wanted a large repertoire and also a resemblance of realism to the listener. For this reason, they did thousands of experiments, condensing the results as suitable combinations of soundboxes, diaphragm material, recording horns (the funnels for collecting the sound), and distances from the recording horns, all of them trade secrets. The record companies had to balance a fine line between background noise and distortion.

The horns used for recording were invariably conical, whereas those for reproduction were mostly flared, although not truly exponential as taught by theory. The recording companies’ musical staff also rearranged the music to support string bass lines by deep brass instruments and specified so-called Stroh instruments for the string section (Stroh, 1900). Instead of a body, they only had a skeleton outline and were fitted with a diaphragm in a huge soundbox. A Stroh violin is shown in **Figure 3**. The diaphragm was activated by the bridge, and the soundbox was connected to a horn that was intended to point in the direction of the recording horn.

There was no meter to determine the recorded level of the sound, and the only reliable measurement was that of the durability of the manufactured record: after how many plays would the wear distortion be so bad as to be uncommercial? This was determined by playing a test record until it broke down. If the count was satisfactory, a whole batch of records would be manufactured. The number varied among companies, but a minimum of 50 reproductions on the company’s own brands of reproducer (gramophones and phonographs) was a requirement. Some combinations of manufacturing procedures, materials, and reproducers could provide as many as 200 reproductions.



**Figure 3.** For recording purposes, J. A. Stroh invented this instrument with the outer dimensions of a violin but with a horn to direct the sound toward the recording horn. The bridge (b) rests on a transverse rocking lever (c) with knife edges (d-d). A lever (not visible) going sideways transmits the vibrations to the center of a large diaphragm in the soundbox (o). The big radiating horn was fitted to the soundbox. From Stroh (1900) patent drawing.

It was discovered that some of the wear was reactive (we would say a mismatch of impedances) and some of the resonances in the stylus-soundbox-horn combination were quite sharp. Thus, one company, the Victor Talking Machine Company, recorded at 76 rpm and specified 78 rpm for reproduction. This effectively staggered the tuning and avoided exciting resonances with signals that were already strongly recorded due to resonances in the recording setup (Brock-Nannestad, 1997). All commercial sound recording developed by trial and error, for instance, a good-wearing groove profile was discovered after examination of innumerable microscopic groove section photographs and relating them to the durability determined by the wear tests.



During the acoustic recording period, the only scientist who early on worked with the type of horn that was used for commercial recording was Dayton C. Miller (1916) at the Case Institute of Technology in Cleveland, OH. He did not analyze horn performance mathematically nor did he work in recording onto a grooved medium, but he established calibration curves when he used conical horns for measuring waveforms from musical instruments by means of his phonodeik. Miller was a consultant to one of the recording companies, Aeolian-Vocalion, quite late in the acoustic period. **Figure 4** shows a collection of phonographs of different manufacture in Miller's laboratory in front of his phonodeik.

Scientific work on the directionality of conical horns, which would have helped in placing the instruments around the recording horn, did not appear until the 1930s (Hall, 1932; Goldman, 1934), too late to make any impact on acoustic recording practices, which had been almost universally abandoned from 1926.



**Figure 4.** Dayton C. Miller was a consultant to Aeolian-Vocalion, a phonograph manufacturer. The photo shows the many types of phonographs that Miller measured and compared. On the brick pedestal (right front) is his calibrated Phonodeik with its conical horn. Photo ca. 1915. Courtesy of Arthur H. Benade, Case Western Reserve University, 1985.

### Early Experiments in Electromechanical Recording and Gradual De Facto Standardization

As the amplifying electronic tube became more common, the idea arose that microphones already known from telephones could be used to collect the sound. At the same time, it was realized that electromagnetic actuation could be used to vibrate the cutting stylus for disc phonograph purposes. The principle had already been used around 1900 for cylinder phonographs, using, in effect, a simple telephone circuit

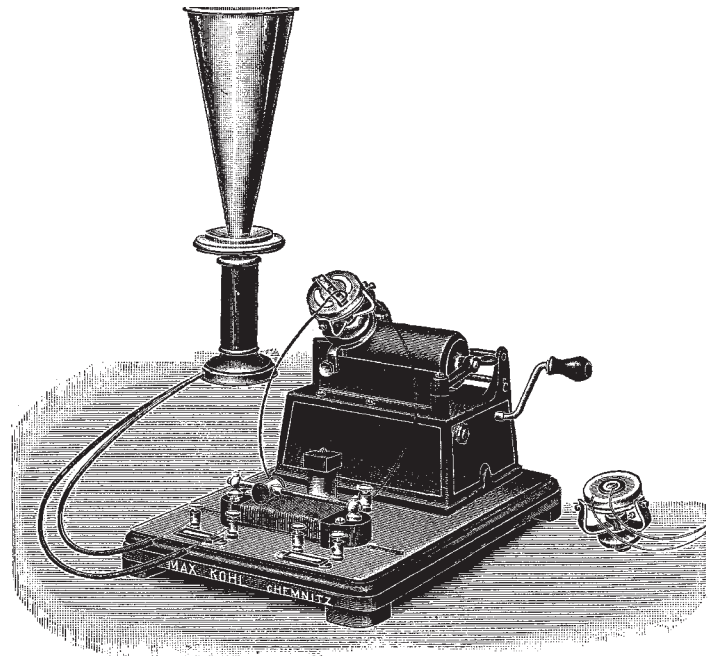
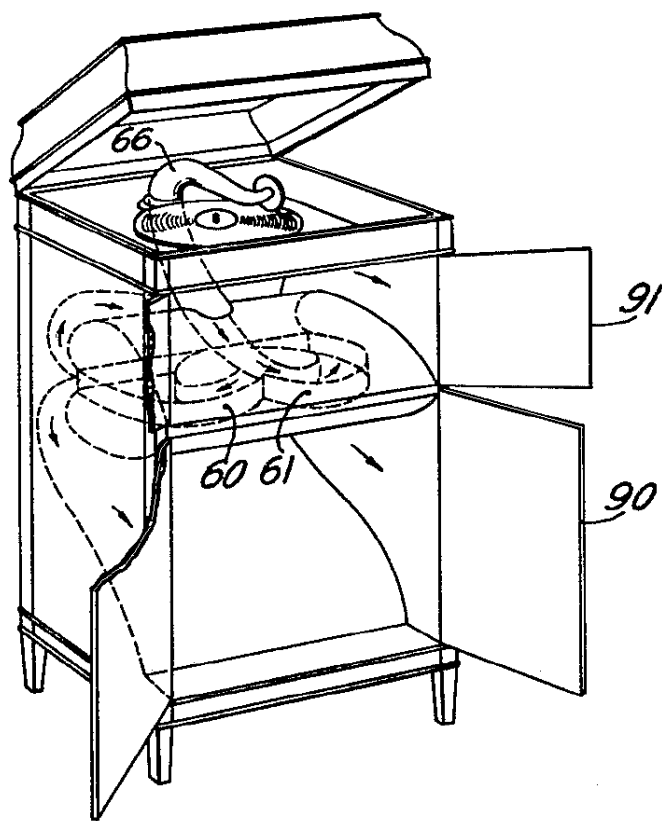

**Figure 5.** A cylinder phonograph with electrical reproduction, 1908. The stylus of the reproducer acts on a carbon granule microphone as used for telephones, and with an electric battery in series, the telephone headset reproduces the sounds from the cylinder through the funnel. From Max Kohl A. G. Chemnitz, Germany, Catalogue No. 50, *Appareils de Physique, Tôme III*, ca. 1920, p. 1055.

with a carbon granule microphone, battery, and phone receiver with a cutting stylus mounted on its diaphragm. A cylinder phonograph reproducing electrically for demonstration purposes is shown in **Figure 5**.

Various approaches were tried, but the surviving system was developed at the Bell Telephone Laboratories in connection with their long-term research into speech transmission and line amplifiers. Maxfield and Harrison (1926) from Bell Laboratories published their design and made very effective use of equivalent circuit diagrams for the electromechanical transducers involved in cutting a record (F. V. Hunt in 1954 considered that this particular use was the very first large-scale application of these principles). At the same time, Maxfield and Harrison also developed the best purely acoustic reproduction system with close control of the masses, elasticities, and cavity volumes as well as the horn. If we compare **Figures 4 and 6**, we can see that outwardly there was not much difference in appearance between the “old” phonographs with an enclosed horn and the new construction 10 years later. However, the performance had been improved remarkably.

By this time, the disc record with lateral modulation had become a de facto standard product, which was playable on any disc phonograph.



**Figure 6.** Disc phonograph designed by Maxfield and Harrison by means of equivalent circuits. The record on the turntable is played by a soundbox connected through a sound conduit to the large horn with its square opening at the front of the phonograph. From Harrison (1930).

The almost revolutionary consequence of electrical recording was that by means of a meter, it was now possible to monitor the volume or amplitude of the signal that was going to be engraved on the master record. This meant that soft passages could be amplified more to provide a signal that was lifted well out of the background noise. And strong passages could be reduced in amplitude to avoid distortion. After 30 years of trial and error that had been required in acoustic recording, it was now possible to obtain a reliable quality. This represented a huge saving in cost.

A marked difference developed between the United States and Europe: the United States was quick to adapt to a purely electrical reproduction with a pickup, amplifier (mostly the amplifier already available in a radio set), and loudspeaker, whereas in Europe acoustic reproduction was common until about 1940. In fact, in 1947 in the United Kingdom, 25% of the reproducing equipment was still acoustic and the record companies had to equalize their recordings correspondingly (Mittell, 1947). In the overseas markets supplied from the United Kingdom (i.e., excluding the United States), the proportion was closer to 75%.

## The Introduction of Acoustic Space Design for Recording Purposes

When the record companies introduced recording large ensembles about 1912, the crowding of musicians around the mouth of the recording horn or horns was very tight and the ambience of the recording studio was rarely captured in a recording. However, as permanent recording installations became the norm, it also became possible to utilize some of the room acoustics. To be able to adapt the room acoustics to the performance, the Gramophone Co. in Hayes, Middlesex, UK, starting about 1912, used a very special recording studio. It had been designed with walls covered in pine and had a ceiling that could be adjusted in height by a rack-and-pinion system. The US partner of the Gramophone Co., which was the Victor Talking Machine Company, had no interest in room ambience, as reported only five years earlier by the chief recording expert of the Gramophone Co., Fred W. Gaisberg, subsequent to a visit. They kept the windows of the recording room open in the summer (Brock-Nannestad, 1997), which would surely have destroyed any reverberation.

When electrical recording took off starting in 1926, the flexibility in microphone placement created a huge change in the approach. Instead of musicians crowding around the recording horn, microphones were placed near the instrument groups, and the soloist was provided with one all to himself/herself.

## The Work on Types of Groove Modulation: Cutterheads and Pickups

The two types of modulation of the groove have already been mentioned: the oldest was the vertical or hill-and-dale, but the commercially surviving modulation was the lateral modulation (sometimes called Berliner; **Figure 1**). When the stereo groove came along in the 1950s, the two (orthogonal) sides of the groove had different modulations, and each was effectively hill-and-dale. However, in professional recording, either in broadcasting or in academic field recordings, the vertical recording prevailed for much of the 1930s. In broadcasting, the fact that the modulation was out of the plane of the record meant that the grooves could be narrower, making space for longer recordings on each side of a record. In field work, acoustic phonographs were frequently still used at the end of the 1930s, the main reason being independence of electrical power. Furthermore, a wax cylinder in its protective box could be less fragile than a recorded instantaneous record in a sleeve. But the phonograph cylinder survived well into the 1960s in its original intended use, office dictation.

In the acoustic period, the cylinder phonograph cutterhead was a soundbox with the diaphragm parallel to the axis of the cylinder with an engraving cutter driven from the center of the diaphragm. When electrical amplification entered the field, the cutterheads or vibrators for driving the cutting stylus were mechanically very much like the moving parts of loudspeakers because they had a high efficiency. This was good for laterally modulated records that required a large amplitude. The electric cutterhead of Maxfield and Harrison was such an advance in the art that it was licensed to the largest record companies. They, in turn, experimented with developing alternative solutions to avoid this patent license. Edward W. Kellogg (1927) from the General Electric Co. gave a very complete overview of all the electromagnetic possibilities for constructing pickups (for getting the signal off the record) and cutterheads (for recording), and most were tried in practice.

Alan D. Blumlein (1934), first at Columbia and then at EMI in the United Kingdom, developed a moving-coil cutterhead that had a one-turn secondary coil as the driving coil, being supplied with modulation from a transformer primary on the same magnetic circuit. This principle had been used 20 years earlier by Reginald Fessenden (1914) for a subaqueous transducer. As piezoelectric salts and efficient moisture sealants were developed, several types of cutterhead were developed, giving a capacitive load with a high electrical impedance to the vacuum tube amplifiers, thereby avoiding an expensive component, the output transformer.

For vertical modulation that required much less amplitude, systems were developed, which were not only linearized by means of negative feedback from the actual movement of the stylus holder but were also given a uniform high mechanical output impedance.

### Instantaneous Recordings

From its inception, the cylinder phonograph with its strong motor was a machine for recording and reproduction, whereas the disc phonograph was only for reproduction and only for suitable and mechanically strong records. There was a drive to avoid the complex manufacturing process when needing to make a permanent disc record. Equipment for moving a cutterhead slowly inward while cutting a spiral groove was well-known (a typical example is shown in **Figure 7**), but a suitable recording medium was required. Around 1930, several types of lacquer-coated flat discs were developed that could be recorded by an electrical cutterhead. The electrical motor supplied with ordinary

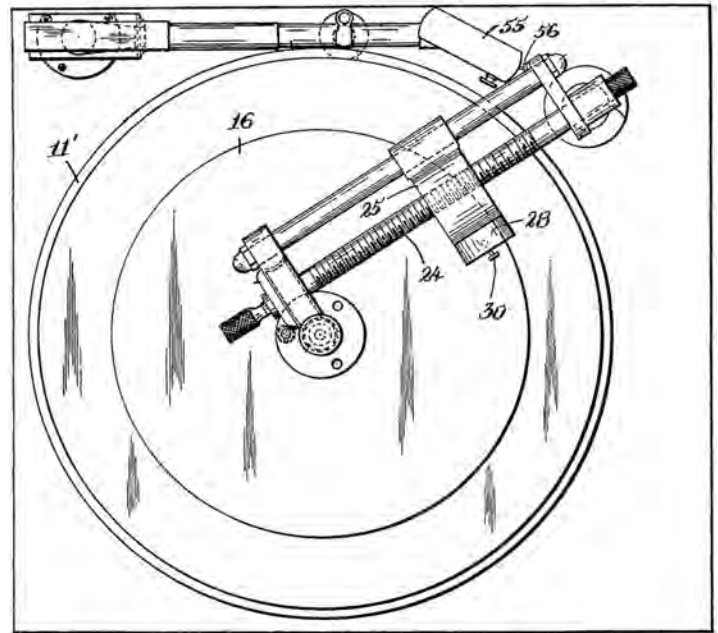

**Figure 7.** Typical recorder with radial feedscrew for instantaneous discs. The rotating turntable turns the feedscrew (24) via a gear, and the cutterhead (30) moves gradually inward while cutting a groove in the blank disc. A separate arm carries a pickup (55) for reproducing the record. Redacted from Goldman (1939).

disc phonographs was not strong enough to enable cutting; therefore the motors had to be stronger. The result was the lacquer record that could be played as soon as it had been recorded without being worn out in the process as the wax did (Brock-Nannestad, 2012).

### The Post-World War II Transfer to Fine-Groove Recordings for Private Consumption and Hi-Fi

From the beginning of the 1930s, the quality of commercial recording was so uniform that very long works like symphonies and operas were recorded full length in sets of 12-in. (30-cm-diameter) 78 rpm records, perhaps 10 or more to a bound booklike album. Although the individual record sides were coupled in ingenious ways to enable a whole stack to be put on a disc phonograph with a record changer, the interruption every 5 min distracted from the illusion of a live performance. For continuity, broadcasting stations used huge 16-in. (40-cm-diameter) discs at  $33\frac{1}{3}$  rpm or, as wealthy customers did, two turntables to make a smooth transition.

With the development of ever lighter pickups and low-noise PVC-based record materials, the thought of a commercial long-playing (LP) record materialized. The CBS subsidiary Columbia Records provided this in 1948 with up to 20 min per 12-in. side at  $33\frac{1}{3}$  rpm. Quite independently in 1949, RCA introduced a system that used 7-in. (17-cm-diameter)



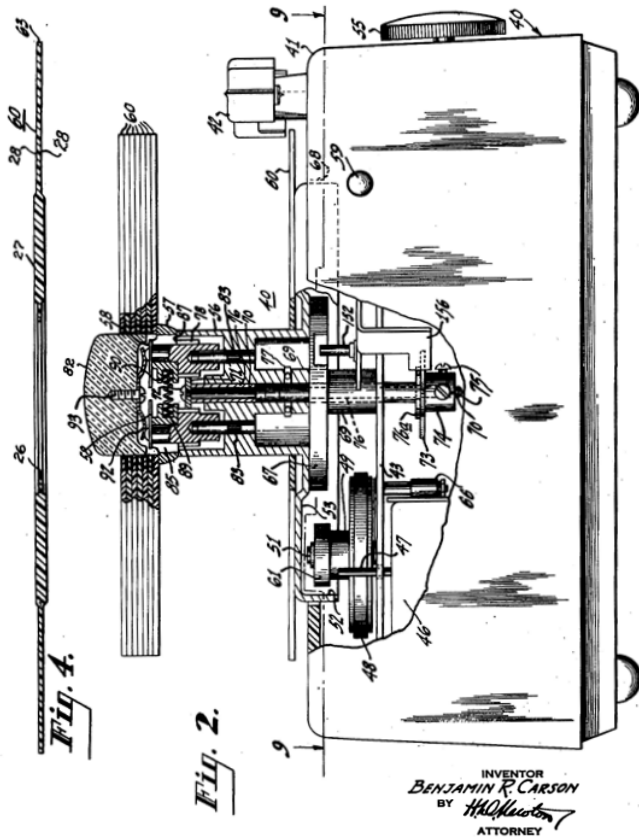

**Figure 8.** RCA's revolutionary record changer (1949) for "singles." This type of record has a cross section with the area (27) so thick that the recorded surfaces (28) outside do not touch when they are stacked on the changing mechanism (82). The next record falls down when one side has been played by means of the pickup (42). From Carson (1953).

records at 45 rpm together with an extremely fast record changer. The mechanism is shown in **Figure 8**. The records were made in a way that scratching did not occur when placing them in a stack (see **Figure 8**, top).

In the consumer market, the large sector, popular music, quickly transferred from 10-in. (25-cm-diameter) shellac to 7-in. vinyl (the "single"), and the LP took the market for "serious" music. As the market developed, popular music compilations of singles could be found on LPs, with a different balance and level commensurate with the more expensive disc phonographs used for LPs. Only much later did the practice develop that a popular music group would premiere an "album" (in reality merely an LP), from which certain individual numbers would subsequently be made available as singles.

This whole development was dependent on the upsurge in magnetic recording because magnetic tape was used for editing LP sides. That is, however, a different story.

Toward the end of our period of interest, the stereo record took over the market (Bachman et al., 1962; Hilliard, 1962). Stereo had been introduced in a two-channel consumer reel-to-reel tape format, but the ease of handling of the LP displaced it. But even the LP was overtaken by a new format that was easier to use in practice, the magnetic tape compact cassette, sometimes called the MusiCassette. The breakthrough of this medium that merely required loading a cassette and pushing a play button occurred in the late 1960s.

### Conclusions

Looking at commercial sound recording and reproduction, we can see that it was always dependent on a huge supporting industry for its components. It was a broad spectrum of contributing industries that was able to evolve from a simple start. Even though present-day sound recording and reproduction activities may amount to little more than finding suitable acoustic spaces and moving computer files representing the sound, this is also very dependent on supporting industries, including a very specialized semiconductor manufacturing base.

### Biosketch



**George Brock-Nannestad** graduated with a degree in signal processing in 1971, focusing on musical acoustics. With public funding from 1981 to 1986, he carried out the project "The Establishment of Objective Criteria for Correct Reproduction of Historical Sound Recordings." From 1991 to 1998, he was responsible for the Media area at the School of Conservation in Copenhagen. Presently, he researches and consults on sound restoration and audiovisual technology history. He was a regular contributor to the AHRC Research Centre for the History and Analysis of Recorded Music from 2004 to 2009 and contributed chapters to *The Cambridge Companion to Recorded Music* (2009) and *The Art of Record Production* (2012).



## References

Bachman, W. S., Bauer, B. B., and Goldmark, P. C. (1962). Disk recording and reproduction. *Journal of the Institute of Radio Engineers* 50, 738-744.

Beranek, L. (1954). Loudspeakers and microphones. *The Journal of the Acoustical Society of America* 26, 618-629.

Bergtold, F. (1959). *Moderne Schallplattentechnik*. Franzis-Verlag, Munich, Germany.

Beyer, R. T. (1999). *Sounds of Our Times: Two Hundred Years of Acoustics*. Springer-Verlag, New York.

Blumlein, A. D. (1934). *Electromagnetic Phonograph Recorder*. US Patent 1,968,806, filed July 29, 1931, and issued August 7, 1934.

Brock-Nannestad, G. (1997). *The Objective Basis for the Production of High Quality Transfers from Pre-1925 Sound Recordings*. Preprint No. 4610, Audio Engineering Society 103rd Convention, New York, September 26-29 1997.

Brock-Nannestad, G. (2007). *150 Years of Time-Base in Acoustic Measurement and 100 Years of Audio's Best Publicity Stunt - 2007 as a Commemorative Year*. Paper No. 7007, Audio Engineering Society 122nd Convention, Vienna, Austria, May 5-8, 2007.

Brock-Nannestad, G. (2012). The lacquer disc for immediate playback: Professional recording and home recording from the 1920s to the 1950s. In Frith, S., and Zagorski-Thomas, S. (Eds.), *The Art of Record Production. An Introductory Reader for a New Academic Field*. Ashgate, London.

Brock-Nannestad, G. (2014). The mechanization of performance studies. *Early Music* 72, 623-630.

Brock-Nannestad, G., and Fontaine, J.-M. (2008). Early use of the Scott-Koenig phonograph for documenting performance. In *Proceedings of Acoustics '08 Paris*, June 29 to July 4, 2008, pp. 6237-6242.

Carson, B. R. (1953). *Automatic Phonograph Record Playing Mechanism*. US Patent 2,634,135, filed March 31, 1949, and issued April 7, 1953.

Fessenden, R. A. (1916). *Dynamo-Electric Machinery*. US Patent 1,167,366 (GB Patent 18,765), filed January 29, 1913, and issued January 4, 1916.

Gilotaux, P. (1971). *Les Disques*. Presses Universitaires de France, Paris.

Goldman, I. H. (1939). *Sound Recording Apparatus*. US Patent 2,174,226, filed September 15, 1937, and issued September 26, 1939.

Goldman, S. (1934). Supersonic measurement of the directional characteristics of horns. *The Journal of the Acoustical Society of America* 5, 181-195.

Hall, W. M. (1932). Comments on the theory of horns. *The Journal of the Acoustical Society of America* 3, 552-561.

Harrison, H. C. (1930). *Acoustic Horn*. US Patent 1,747,830 (GB Patent 252,657), filed October 6, 1928, and issued February 18, 1930.

Hilliard, J. K. (1962). The history of stereophonic sound reproduction. *Journal of the Institute of Radio Engineers* 50, 776-780.

Hoffmann, F. (Ed.). (2005). *Encyclopedia of Recorded Sound*, 2nd ed. Routledge, New York.

Hunt, F. V. (1954). *Electroacoustics: The Analysis of Transduction, and Its Historical Background*. Harvard University Press, Cambridge, MA. Reprinted by the Acoustical Society of America, Melville, NY, 1982.

Kellogg, E. W. (1927). Electrical reproduction from phonograph records. *Transactions of the American Institute of Electrical Engineers* 46, 903-911.

Maxfield, J. P., and Harrison, H. C. (1926). Methods of high quality recording and reproducing of music and speech based on telephone research. *Transactions of the American Institute of Electrical Engineers* 45, 334-346.

Miller, D. C. (1916). *The Science of Musical Sounds*. MacMillan, New York.

Mittell, B. E. G. (1947). *Commercial Disc Recording and Processing*. Informal Lecture Delivered to the Radio Section of the Institution of Electrical Engineers on 9 December 1947. Published privately by EMI Ltd., London.

Nixon, G. M. (1945). "Higher fidelity" in sound transmission and reproduction. *The Journal of the Acoustical Society of America* 17, 132-135.

Olson, H. F. (1954). A review of twenty-five years of sound reproduction. *The Journal of the Acoustical Society of America* 26, 637-643.

Pantalony, D. (2009). *Altered Sensations: Rudolph Koenig's Acoustical Workshop in Nineteenth-Century Paris*. Springer, New York.

Parsons, C. A. (1906). *Sound Reproducer or Intensifier Applicable to Phonographs, Gramophones, &c*. US Patent 817,868 (GB Patent 10,468 of 1903), filed April 12, 1904, and issued April 17, 1906.

Stroh, J. M. A. (1900). *Violin or Other Stringed Instrument*. US Patent 644,695, filed August 21, 1899, and issued March 6, 1900.

### One Tube One Sample One Measurement



**Spectronics, inc**  
www.spectronics.net



- Sound absorption, impedance measurement
- TL of barrier materials and mufflers
- Conforms to American and international standards
- Software works with your analyzer or
- Use our DAQ unit for a standalone system
- Uses standard 1/2 or 1/4 inch microphones

2100 Elgin Pl., Lexington, KY 40515  
Tel: 859-321-1843 • info@spectronics.net