

THE ASA CLASSROOM ACOUSTICS EFFORT

Peggy B. Nelson

Department of Speech-Language-Hearing Sciences
University of Minnesota
Minneapolis, MN 55455

One of the most rewarding recent efforts of the ASA has been our involvement in the development of the classroom acoustics standard (ANSI, 2002). The accomplishment was a true joint venture, involving contributions from experts in speech perception, psychoacoustics, architectural acoustics, engineering acoustics, physical acoustics, noise control, and others. The standard's development was the epitome of a team effort, with contributions from academicians and researchers as well as industry representatives and product manufacturers. Particular thanks are due to the co-chairs of the working group, Lou Sutherland and David Lubman. Additional thanks go to the staff of the ASA Standards organization, in particular Daniel Johnson, Susan Blaeser, and Paul Schomer. The beneficiaries of this joint effort will include children learning in quieter spaces around the country.

Hard-working ASA members of the standard's working group are listed in the table. The working group also included representatives from industry, consumer advocacy groups, government agencies, architects, teachers' unions, and other interested associations. The group met periodically for at least two years. Throughout the meetings the panel extensively discussed the literature, design principles, costs, and proposed performance criteria. Discussions were lively and heated, and it should be no surprise that we occasionally moved backwards before moving forward again. Ideas were included and later discarded as the focus of the proposed standard became clearer. In December 2001 the task force agreed upon a final version of the standard that was soon approved by the American National Standards Institute. The new standard immediately met with controversy, receiving a last-minute challenge from certain industries (modular classrooms, Air-conditioning and Refrigeration Institute). Nevertheless, the standard was adopted and is now embraced by some of those early "opponents."

In this brief article, I hope to explain the basic principles of the standard, summarize the rationale and need, and show examples of how it is working around the country. This information should provide ASA members with the information they need to be advocates for the standard in their own communities and schools. In the paragraphs below I will address questions about the standard that I frequently hear from constituent groups.

Did we really need a new standard for acoustics in classrooms?

As the working group started to meet, it quickly became apparent to the members that the current status of acoustics in schools was unsatisfactory for children's learning. Surveys of noise and reverberation in existing unoccupied classrooms commonly reported background noise levels of 50 – 65 dBA (e.g., Knecht *et al.*, 2002) in both newer and older schools in urban, suburban, and rural school districts. Primary sources of unoccupied classroom noise included classroom appliances (especially heating, ventilation, and air-conditioning (HVAC) systems), traffic noise entering through the building's exterior, and school noise emanating from a classroom's adjacent hallways and spaces. Average reverberation times (RT60 for .5, 1, and 2k Hz) varied from 0.4 s to as long as 1.5 s. Although many classrooms had acceptable RTs (0.6 s and below), high ceilings in older classrooms resulted in long RTs and significant temporal smearing of speech signals (see Nabelek and Nabelek, 1985 or Nelson, Soli, and Seltz, 2003, for a description of temporal smearing due to reverberation.)

With background noise levels such as those measured, it could be expected that target voices, such as the teacher's voice, frequently arrive at students' ears around the room at signal-to-noise ratios (SNRs) as low as 0 dB. Basic estimations suggest that if a teacher's voice starts at an expected rms of 65 dBA, and is then reduced by the distance between the source and the student, the voice level and the level of the background noise may be approximately equal at locations farthest from the source. In fact, direct measurement of SNR in classrooms suggests just that, that the SNR for students

Fig. 1. Speech recognition thresholds in noise for children and adults (from Soli and Sullivan, 1997). Using the Hearing in Noise Test (HINT), one can see a systematic improvement in speech recognition thresholds as listeners develop into adolescence and adulthood.

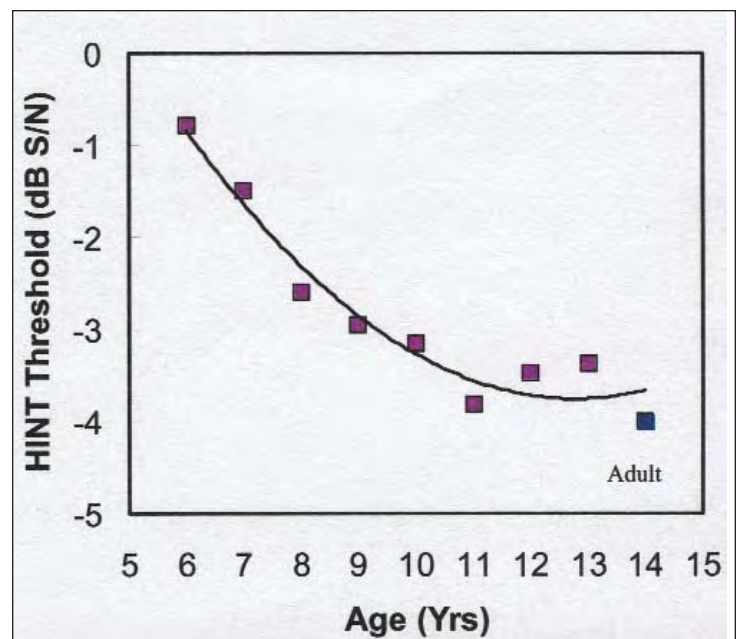

closest to the source are most favorable, but for those a few meters from the source, the SNR can approach zero. A number of research reports (including Soli and Sullivan, 1997) have shown that while adults can understand familiar speech under conditions of an SNR = 0 dB, children cannot.

It does not appear, then, that classrooms are being built with the acoustic needs of children in mind. It seemed clear to the working group that a standard could lead the way toward more favorable learning conditions for students.

How do teachers handle classroom noise?

Teachers seem aware of the noise problem in schools, and adapt their teaching styles to compensate for poor acoustics. In a government survey, teachers reported that classroom noise was the most common building facilities problem they faced (U.S. GAO report, 1995). Teachers in the Los Angeles Unified School District told working group members in 1999 that they were forced to alternate time between teaching and child comfort when noisy window air-conditioning units were installed in thousands of classrooms. Teachers report frequent voice problems as they attempt to overcome background noise problems in their classrooms. Smith *et al.* (1998) reported that 32% of teachers reported occasional voice problems, with 20% reporting that they had missed work occasionally because of vocal fatigue.

Some school districts have turned to electronic amplification systems to attempt to increase the teacher's source voice level above that of the background noise. Although amplification systems can be helpful under specific circumstances (especially lecture-style classrooms in nonreverberant spaces), they have obvious limitations for active, child-based learning strategies where multiple signal sources need to be heard. (Recall for a moment the last large-group meeting you attended in which certain members refused to wait for the microphone to be passed when speaking.) In addition, it seems obvious that if walls dividing classrooms are insufficient for noise reduction, amplifying two rooms on opposite sides of this inadequate wall would not provide a satisfactory solution. Also, based on well-controlled studies of speech in noise at a range of overall levels, we firmly believe that quieter is better. Even if one could provide a strong, positive signal-to-noise ratio by elevating individual voice levels above background noise levels of 65 dBA, considerable research suggests that this is not optimal for speech recognition (Studebaker *et al.*, 1999) nor for student and teacher fatigue. The best solution to all of these problems is to build quiet schools in the first place.

Members of the working group, then, were convinced of the need for improved acoustics in schools. We then looked for evidence that would guide the setting of performance

“It does not appear...that classrooms are being built with the acoustic needs of children in mind. It seemed clear to the working group that a standard could lead the way toward more favorable learning conditions for students.”

standards so that students could be assured full acoustic access to the spoken messages in classrooms.

Why do children need favorable acoustics?

The first, most overwhelming finding of the extensive literature search was that all children need favorable acoustics for learning. It seems clear from extensive research that children do not detect, discriminate, and understand signals in background noise and reverberation in the same way as do adults. Children are significantly more negatively affected by noisy and reverberant rooms than are adults in those rooms. The younger the child, the more negative are the

effects of background noise and reverberation. Adult performance levels, then, should not dictate the acoustic needs of children in schools.

This article is not intended to be a detailed description of the research supporting these claims. (For more detailed summaries and thorough bibliography for this material, please refer to Nelson, Soli, and Seltz, 2003). Briefly, though, several theories of developmental psychoacoustics have emerged that may explain the findings. Much of this good theoretical work in developmental psychoacoustics has been done by members of the ASA. Some of this excellent work will be referenced here.

A consistent finding throughout the studies of young children is that children start as inefficient listeners and continue to develop as selective listeners well into adolescence. As young infants, children seem to be nonselective-broadband listeners who are equally adversely affected by background noises of all types. They don't yet know what signals to ignore and when to focus attention. Adults typically experience masking from narrow bands of noise that are similar in frequency to the target sound (energetic masking). When two sounds (a masker and a target) that are close in frequency reach the cochlea (inner ear) the two stimulation patterns overlap. The presence of the masker sound, then, diminishes the ability to detect the target signal. For infants and young children, however, the stimulation patterns need not overlap in order for one sound to interfere with the detection of another. Even when a noise is remote in frequency from the target sound and the excitation patterns are well separated from one another, the infant is less likely to detect the target sound (Werner and Bargones, 1991).

At times adults are confused and distracted by complex background noise, even when that noise does not cause energetic masking in the cochlea. Wightman *et al.* (2003) recently showed that adults and children can experience significant amounts of masking by pure tone complexes, even when those tones are not close in frequency to the target signal tone. This has been called “informational” as opposed to “energetic” masking. In their investigation, younger children

experienced large amounts of informational masking even when the masking tones were presented to the ear opposite the one hearing the signal. Adults experienced much less informational masking, and when the signal and masking tones were presented to opposite ears, the masking tones had no effect on tone signal detection. The children, then, were apparently unable to ignore irrelevant sounds, even when they were heard in the “wrong” ear.

Children apparently also do not ignore echoes in reverberant rooms (Litovsky, 1997). Although children can localize simple single sounds as well as do adults, when sounds have leading and lagging elements typical of reverberant rooms, children do not fuse those sounds into one image, as do adults. This may suggest that children are attending to the initial sound and its echo as independent sound sources. They have not yet learned to ignore the irrelevant echo.

Studies of children’s neurobiology suggest that the behavioral patterns seen in these studies are reflected in the neurological patterns in the brain. Patterns of neural excitation change as children age. The patterns become less diffuse and more specific as children age into adolescence and beyond. Recent results suggest that complex neurological changes, including integration of information from the senses, continue until the brain is fully mature, some time in the third decade of life (Giedd, 2004). Until neurological centers mature, children are more adversely affected by background noise and require more favorable SNR to fully recognize speech.

During the first years of life, infants and young children are also learning to selectively attend to the important sound patterns of their native language. In the first months of life, infants are equally sensitive to patterns and phonemes from all languages equally well. Within a few months, however, toddlers become better at detecting familiar phonetic patterns, and “lose” the ability to discriminate unfamiliar phonemes from other languages (Werker *et al.*, 1981, Kuhl, 1991). Infants seem to be going through a period of developing selective attention for speech sounds used by their immediate caregivers. Nitttrouer (1996) has shown that throughout childhood children continue to learn and develop adult-like patterns of listening and attention that make them more efficient at understanding speech in their native language. At first, children pay attention to parts of the speech signal that are less reliable than others, but gradually they learn to use the acoustic information in adult-like ways. Children also don’t seem to be able to fill in missing information, using their knowledge of the language. When words are completely audible, children are able to identify the words nearly as well as adults; when the audibility of the words is reduced somewhat, however, adults can identify the partially audible words quite well, while children cannot (Stelmachowicz *et al.*, 2000). The difference between children and adults for understanding partially heard words is quite remarkable. Children apparently do not use the partial information they hear to fill in the missing information. The younger the child, the larger the difference between their recognition and adult performance.

All of these data strongly suggest that all children require

more favorable acoustics than do adults for the kind of auditory learning that goes on in classrooms every day. Children are not just being unpredictably inattentive or easily distractible; they are children, whose auditory systems are immature and still under development. (As one of my favorite father/teachers is fond of saying: “Children are so juvenile!”) Children start out life apparently wired to take in every sound and every language, and their experience shapes them into more efficient, focused listeners. Typically developing children need acoustic conditions that allow them full, stable access to auditory signals in schools so that no matter where they sit in a classroom, they can hear every word.

Are some children more vulnerable to poor acoustics than others?

A second important finding is that children with special needs constitute a large proportion of the school populations and these children need even more favorable acoustics. In particular, children who are learning English (who speak other languages at home) seem to be particularly vulnerable to background noise and reverberation. Children who are learning new speech sounds and speech contrasts (for example, “b” versus “v” for children who speak Spanish) require a more favorable signal-to-noise ratio than those who are functioning more comfortably in their first language (Nelson *et al.*, 2005). All world travelers who have struggled to converse in noisy restaurants in unfamiliar languages can recall that background noise affects non-native listeners more than the locals. This need for favorable acoustics has been well quantified in the literature for adults (e.g., Mayo, Florentine, and Buus, 1997). We know less about the needs of children (e.g., Crandell and Smaldino, 1996; Nelson *et al.*, 2005) but it appears that children learning in a second language environment experience a kind of double jeopardy in noisy classrooms that is related to their incomplete development as well as their unfamiliarity with a new language. In major cities around the country, children who speak other languages may constitute as many as 30–40% of a public school population.

Surprising numbers of school-aged children have some degree of hearing loss. Public health studies of thousands of children suggest that slight, sensorineural (inner ear) hearing loss is found in approximately 15% of the school population. Hearing loss, also, magnifies the detrimental effects of background noise and reverberation. In addition to having decreased sensitivity for soft sounds, all people with sensorineural hearing loss have poorer auditory frequency resolution, making masking noises more effective. Adults with sensorineural hearing loss report that they tolerate less background noise than expected simply on the basis of their reduced sensitivity to sound (Plomp, 1978). Children with hearing loss, then, can also be expected to experience the double effects of incomplete development and hearing loss. Children with other special needs also experience detrimental effects of noise. These include children with hyperactivity/attention deficit disorder, as well as other auditory learning disorders. Evidence suggests (e.g., Warrier *et al.*, 2004) that these children, too, are especially distracted by class-

ASA MEMBERS OF ANSI W/G S12.42

| | | |
|----------------------|-----------------------|---------------------|
| Robert E. Apfel | Murray R. Hodgson | Daniel Queen |
| John S. Bradley | K. Anthony Hoover | Stephen I. Roth |
| Bennett M. Brooks | Daniel L. Johnson | Kenneth P. Roy |
| Daniel C. Bruck | Howard F. Kingsbury | Mark E. Schaffer |
| Angelo J. Campanella | Jerry G. Lilly | Neil T. Shade |
| Robert C. Coffeen | Harold L. Merck | Gary W. Siebein |
| T. James DuBois | Peggy B. Nelson | Joseph J. Smaldino |
| Stanley L. Ehrlich | Michael T. Nixon | Sigfrid D. Soli |
| John Erdreich | Stephen W. Payne, Jr. | Noral D. Stewart |
| Richard D. Godfrey | Karl S. Pearsons | Brandon D. Tinianov |
| William H. Hannon | Richard J. Peppin | Ewart A. Wetherill |
| Robert D. Hellweg | Joseph Pope | William A. Yost |

NON-ASA MEMBERS OF ANSI W/G S12.42

| | | |
|-------------------|-------------------|-------------------|
| Karen L. Anderson | Steve Inglis | Linn Redden |
| Daniel Collings | Cheryl D. Johnson | Anne Seltz |
| Carl C. Crandell | John Lyons | Linda L. Semesky |
| Gary Ehrlich | Ronald Moulder | Donna L. Sorkin |
| David Fagen | Julie Olson | Sarah J. Woodhead |
| Jay J. C. Gould | Richard Randall | |

room noise. These special populations of children constitute a significant proportion of typical public school classrooms, and they should be a consideration in the acoustical design. Nevertheless, good acoustics are needed by all children.

What agreement do we have for the limits to background noise and reverberation that children need?

The working group engaged in extensive discussion of the recommended performance standards. Guidance was sought from research, from other agencies concerned with hearing in children, and from other countries engaged in this dialogue. Based on the literature, children do not reach maximum performance for recognizing familiar speech in background noise at SNRs of +10 dB or less. A common finding amongst researchers was the need for +20 dB SNR. As we surveyed other organizations (such as the American Speech-Language-Hearing Association, or ASHA) and other countries' standards (such as England, Sweden, and Croatia), we found a common desire for at least +15 dB SNR for children to achieve their maximum performance potential. One must consider the need for +15 dB SNR throughout a classroom, and the fact that the average sustainable comfortable conversational speech level of 65 dBA at one meter's distance. Speech is a highly complex signal that varies in frequency and level quickly during conversational speech. Even when one speaks at a relatively constant overall level, individual phonemes in a sentence vary in level by 30 to 40 dB. A sentence that is produced at an average level of 65 dBA, then, may contain vowels that are as high as 75–80 dB and consonants as low as 45–50 dB. In addition, one must assume that voice levels decrease with increasing distance. With these assumptions, the performance criterion of maximum noise levels of 35 dBA (55 dBC) was recommended. Other agencies had recommended more strict criteria (ASHA and the Swedish working group

initially recommended maximum background noise levels of 30 dBA, for example); some advocated for less. Nevertheless, we have learned that a number of countries have converged on the same background noise recommendation.

The working group also considered several possible standards for maximum reverberation time. Data from Nabelek and Nabelek (1985) and others suggested the shorter the recommended RT_{60} , the better for speech recognition. When the RT_{60} approaches .5 s or shorter, few detrimental effects on speech recognition have been noted. When RT_{60} is very short, sound quality may decrease. The working group agreed that recommending a maximum RT_{60} of 0.6 s for unoccupied classrooms would almost certainly result in a lower RT for occupied rooms, once children and furniture were in place. That value also seemed

feasible to achieve in real rooms without extensive modification. Again, other organizations (such as ASHA) had recommended stricter or similar criteria.

The quest for good school acoustics seems to have picked up speed around the world. We know of acoustics standards in Sweden, Germany, the United Kingdom, Italy, Portugal, and Croatia. Some countries are farther along in their implementation of an acoustics standard for schools. The United Kingdom has implemented a mandatory standard for new construction. The World Health Organization has compiled recommendations for its European region. The word about children's need for good acoustics seems to be spreading.

How much does it cost?

We recognize that building schools to meet this standard will not happen without some additional cost. To meet the acoustical needs of children, designers will need adequate partitions, windows, and doors to control the sound levels of intruding noise from outside the classroom. Beyond that, the HVAC systems seem to present the greatest challenge. Manufacturers of central, ducted HVAC systems are currently meeting that challenge by offering quiet systems that will meet the standard. Estimates for the increased cost of including these high-quality doors and windows as well as central ducted HVAC systems have been between 1% and 3% of construction costs. The United Kingdom reports that it is able to build quiet schools for less than 1% additional cost. It seems a good trade-off for providing full acoustic access to all children. Additional information about costs can be found at www.quietclassrooms.org in the list of links below.

What's next?

The standard has been making news. Efforts are underway in several states to include the standard in future building codes for new school construction. The U.S. Department

of Education estimates that about \$20 billion dollars are soon to be invested in school construction around the country. Planners in Minneapolis are taking a look at the standard as they design new schools. Architects who designed the Burroughs School in Minneapolis received accolades for their attention to acoustical detail (*The Wall Street Journal*, 2003.) More and more, acoustical design seems to be a part of the planning process. The Acoustical Society can be proud of its efforts to make that happen, and proud of the continued efforts to see that the standard is recognized and used for new school construction.**AT**

References

American National Standards Institute (2002) Standard 12.60-2002: Acoustical Performance Criteria, Design Requirements, and Guidelines for Schools. American National Standards Institute, 1819 L Street NW, Suite 600, Washington, D.C.

Crandell, C., and Smaldino, J. (1996). Speech perception in noise by children for whom English is a second language. *American Journal of Audiology* **5**, 47–51.

Giedd, J.N. (2004). Structural magnetic resonance imaging of the adolescent brain. *Annals of the New York Academy of Sciences* **1021**, 77–85.

Knecht, H., Nelson, P., Whitelaw, G., and Feth, L. (2002). Structural variables and their relationship to background noise levels and reverberation times in unoccupied classrooms. *American Journal of Audiology* **11**, 65–71.

Kuhl, P. (1991). Human adults and human infants show a “perceptual magnet effect” for the prototypes of speech categories, monkeys do not. *Perception and Psychophysics* **50**, 93–107.

Litovsky, R.Y. (1997). Developmental changes in the precedence effect: Estimates of minimal audible angle. *Journal of the Acoustical Society of America* **102**, 1739–1745.

Mayo, L., Florentine, M., and Buus, S. (1997). Age of second-language acquisition and perception of speech in noise. *Journal of Speech Language Hearing Research* **40**, 686–693.

Nabelek, A. and Nabelek, I. (1985). Noise and reverberation in rooms, in Katz, ed., “Handbook of Audiology,” 2nd edition, Williams & Wilkins, New York.

Nelson, P., Kohnert, K., Shaw, D., and Sabur, S. (2005). Classroom noise and children learning through a second language: Double jeopardy? *Language, Speech, and Hearing Services in Schools* **36**, 219–229.

Nelson, P., Soli, S., and Seltz, A. (2003). Classroom Acoustics II: Acoustical barriers to learning. A publication of the Speech Communication Technical Committee of the Acoustical Society of America.

Nittrouer, S. (1996). Discriminability and perceptual weighting of some acoustic cues to speech perception by 3-year-olds. *Journal of Speech and Hearing Research* **39** (2), 278–297.

Plomp, R. (1978) Auditory handicap of hearing impairment and the limited benefit of hearing aids. *Journal of the Acoustical Society of America* **63**, 533–549.

Smith E., Lemke, J., Taylor, M., Kirchner, H.L., and Hoffman, H. (1998). Frequency of voice problems among teachers and other occupations. *Journal of Voice* **12**, 480–488.

Soli, S.D., and Sullivan, J.A. (1997). Factors affecting children’s speech communication in classrooms. *Journal of the Acoustical Society of America* **101**, 3070.

Stelmachowicz, P.G., Hoover, B.M., Lewis, D.E., Kortekaas, R.W., and Pittman, A.L. (2000). The relation between stimulus context, speech audibility, and perception for normal-hearing and hear-

ing-impaired children. *Journal of Speech, Language and Hearing Research* **43**, 902–914.

Studebaker, G., Sherpecoe, R., McDaniel, D. and Gwaltney, C. (1999). Monosyllabic word recognition at higher-than-normal speech and noise levels. *Journal of the Acoustical Society of America* **106**, 2431–2444.

U.S. General Accounting Office, Health, Education, and Human Services Division (1995). “Conditions of America’s Schools,” Document#: GAO/HEHS-95-61, Report # B-259307, February 1. *The Wall Street Journal* Marketplace, July 30, 2003, “School districts spend to ensure good acoustics.”

Warrier, C., Johnson, K., Hayes, E., Nicol, T., and Kraus, N. (2004). Learning impaired children exhibit timing deficits and training-related improvements in auditory cortical responses to speech in noise. *Experimental Brain Research* **154**, 431–441.

Werker, J. Gilbert, J., Humphrey, K., and Tees, R. (1981). Developmental aspects of cross-language speech perception. *Child Development* **52**, 349–355.

Werner, L. and Bargones, J. (1991) Sources of auditory masking in infants. *Perception and Psychophysics* **50**(5), 405–412.

Wightman, F., Callahan, M., Lutfi, R., Kistler, D, and Oh, E. (2003). Children’s detection of pure-tone signals: informational masking with contralateral maskers. *Journal of the Acoustical Society of America* **113**, 3297–3305.

Links of interest

www.nimh.nih.gov/press/prbrainmaturing.cfm
(NIMH: Imaging study shows brain maturing)

[www.teachernet.gov.uk/management/resourcesfinanceandbuilding/schoolbuildings/designguidance/sbenvironmentalhs/acoustics\(UKclassroomacousticsbulletin\)](http://www.teachernet.gov.uk/management/resourcesfinanceandbuilding/schoolbuildings/designguidance/sbenvironmentalhs/acoustics(UKclassroomacousticsbulletin))

www.quietclassrooms.org/ada/ada.htm
(check here for Listening for Learning tips from the U.S. Access Board)

Peggy B. Nelson is an Associate Professor of Audiology in the Department of Speech-Language-Hearing Disorders at the University of Minnesota. She was a member of the ASA working group on classroom acoustics, and has worked for the adoption of the ANSI standard as a guide for new construction in Minnesota schools. She teaches and does research in the areas of speech perception in noise for listeners with hearing loss.

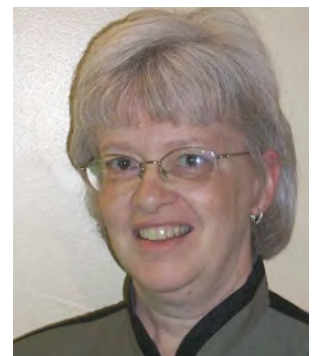

THE CLASSROOM AMPLIFICATION CHALLENGE TO ANSI S12.60-2002

David Lubman

David Lubman and Associates
Westminster, CA 92683

Surveyors of sound amplification systems are mounting a very serious threat to the classroom acoustics standard—ANSI S12.60-2002. As discussed below, these amplification systems address some of the same issues as the American National Standards Institute (ANSI) standard but provide limited benefits.

America wants to improve the educational achievement and inclusiveness of its schools, and implementation of the ANSI standard promises this. ANSI-compliant schools are far friendlier places for teaching and learning than noisy schools. ANSI-compliant schools are also more inclusive, accommodating the needs of millions of mainstream students who are disadvantaged by mild hearing, language, or other learning disabilities.

One reason for the large number of disadvantaged mainstream students is that America is once again a nation of immigrants. English language learners must hear and understand spoken words in classrooms as a prerequisite to learning. Yet, an estimated two-thirds of American classrooms fail to meet minimum requirements of the ANSI standard. The burden of that failure falls first upon disadvantaged students, teachers, and parents. Ultimately, the cost is borne by all.

Today's challenge is to bring about widespread implementation of the ANSI standard. Implementation seems daunting to schools. For decades, American schools operated with weak noise guidelines such as the California Department of Education's 50-dBA classroom noise limit—or none at all! After decades of disregarding the importance of acoustics to learning, favorable buzz about the standard is awakening schools to the benefits of good acoustics. Some school authorities now actually desire good acoustics, but fear the costs and

“The ... choice ... is between amplified classrooms with poor acoustics and unamplified ANSI-compliant classrooms”

technical challenges of designing and renovating schools to satisfy ANSI's 35-dBA noise limit.

Classroom acoustics advocates are pleased that the ANSI standard is awakening schools to the acoustical needs of students and teachers. Unfortunately, in earlier battles over approval of the standard, industry adversaries spread disinformation to school administrators and state legislatures outrageously exaggerating the cost and challenge of compliance with ANSI's 35-dBA noise limit. This made schools vulnerable to slick hawkers of amplifiers that promise good speech intelligibility and teacher voice relief without meeting ANSI requirements for low noise and reverberation.

To paraphrase H.L. Mencken's observation, for every problem there is a solution that is fast, painless ... and wrong! Classroom amplification is a quintessential example of Mencken's observation. Unfortunately, many school decision makers don't see through the honeyed words of amplifier salespeople. Many choose the classroom amplification “band-aid” over good acoustics.

We agree that amplifiers are needed in auditoriums, very large lecture rooms, and in special education rooms for hearing-impaired students. But we cannot justify their use in small lecture rooms intended for mainstream students. And we deplore their use as a substitute for good acoustics.

How did the amplifier challenge come about? For years, vendors provided classroom amplification systems to satisfy the need for elevated speech levels in special education rooms for hearing-impaired students. Perhaps to enlarge that limited market, some vendors of “free-field systems” (as classroom amplifiers are termed) are now aggressively promoting their use in mainstream classrooms.

There are too many mainstream classrooms in which students cannot understand what their teacher is saying because of noise and reverberation, and where teachers suffer vocal fatigue from the effort of speaking above classroom noise. These situations arise because of poor classroom acoustics. These are the very problems the ANSI standard is meant to prevent or remedy. Are amplifiers a valid alternative for good classroom acoustics?

Actually even classroom amplifiers work better with good acoustics (low noise and reverberation). But amplifiers are unsatisfactory substitutes for good acoustics. We believe it is wrong to promote amplifiers as universal panaceas for all classroom acoustical problems.

Advocates of good classroom acoustics claim improved student achievement and behavior and reduced teacher voice fatigue. Amplifier hawkers cite testimonials and studies claiming the same educational benefits for amplifiers. The real choice schools are making is between amplified classrooms with poor acoustics and unamplified ANSI-compliant classrooms. Here is a short list of the advantages of ANSI compliance versus amplification.

- ANSI-compliant classrooms don't need amplifiers. Students and teachers hear each other without strain or fatigue.
- Amplification has limited benefits

in non-ANSI-compliant classrooms.

- Amplification inhibits classroom spontaneity. Students must overcome inhibitions and request or wait for a microphone. They must be also taught effective microphone skills, which is especially difficult in lower grades.
- There are problems and limitations of indiscriminate installation. One example: amplifiers are often installed in excessively reverberant classrooms where amplification is known to be ineffective. Another example: high levels of amplified sound leak through poorly insulated walls to interfere with learning in adjacent classrooms.
- ANSI compliance is a pay-once solution. Amplifiers have continuing costs.

It may be true that the costs, effort, and time needed to achieve ANSI compliance in classroom renovations

exceed the initial cost of classroom amplifiers. The false perception that amplifiers are a fast and inexpensive solution to all classroom acoustic problems is exploited by amplifier salespeople. Without knowledgeable persons to challenge these claims, who can blame school administrators for falling for the pitch? This may explain how amplifier lobbyists in Ohio evidently secured legislation ensuring that all future classrooms in their state are pre-wired for amplifiers. We believe that Ohioans—and all Americans—would be better served by legislating ANSI-compliant classrooms.

Bridget Shield of London's South Bank University was asked recently about her experience with classroom amplification in the UK. Her answer was devastating:

“What we are finding is that most of the systems ... are not used or are used incorrectly as they have broken cables or have not been installed correctly or teachers have not been trained in their use. Or ... they are installed in

rooms with poor acoustics where they are ineffective and the rooms should be acoustically treated.”

With time and experience, schools will overcome their fears of the costs of ANSI compliance. This will make them less vulnerable to the false panacea of classroom amplification. But in the short run, advocates of good classroom acoustics must spread the word. We need to get our message to school decision makers as compellingly as amplifier vendors and lobbyists: Classroom amplification is not a substitute for good acoustics.[AT](#)



David Lubman is an acoustical consultant/scientist in Orange County, California specializing in architectural acoustics and noise. He was co-chair (with Louis C. Sutherland) of the ANSI working group that developed the influential classroom acoustic standard, ANSI S12.60-2002.

Lubman's research helped standardize sound power measurements that is now widely used for rating HVAC equipment noise. He was senior editor of the book *Acoustics of Worship Spaces*, published by the American Institute of Physics in 1985. He is a founder of a new acoustical field, archaeological acoustics. A Fellow of the Acoustical Society of America, Lubman served in many elected and appointed positions in the acoustics community. He was an ASA Executive Councilman and chaired its technical committee on Architectural Acoustics. In May 2004, Lubman was awarded the Society's Helmholtz-Rayleigh Interdisciplinary Silver Medal in Acoustics. He now chairs the National Council of Acoustical Consultant's Honors and Awards Committee.

6,745,149

43.50.Gf ACOUSTICAL NOISE REDUCING ENCLOSURE FOR ELECTRICAL AND ELECTRONIC DEVICES

Todd W. Beeten, Nashville, Tennessee
1 June 2004 (Class 702/132); filed 3 July 2001

Although there appear to be many commercially available examples of

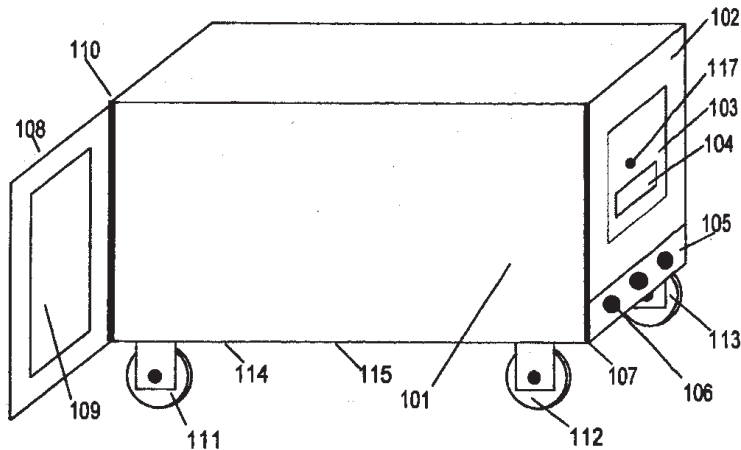

this type of device available (enter the appropriate keywords in your favorite search engine), a patent was issued nonetheless.—NAS